

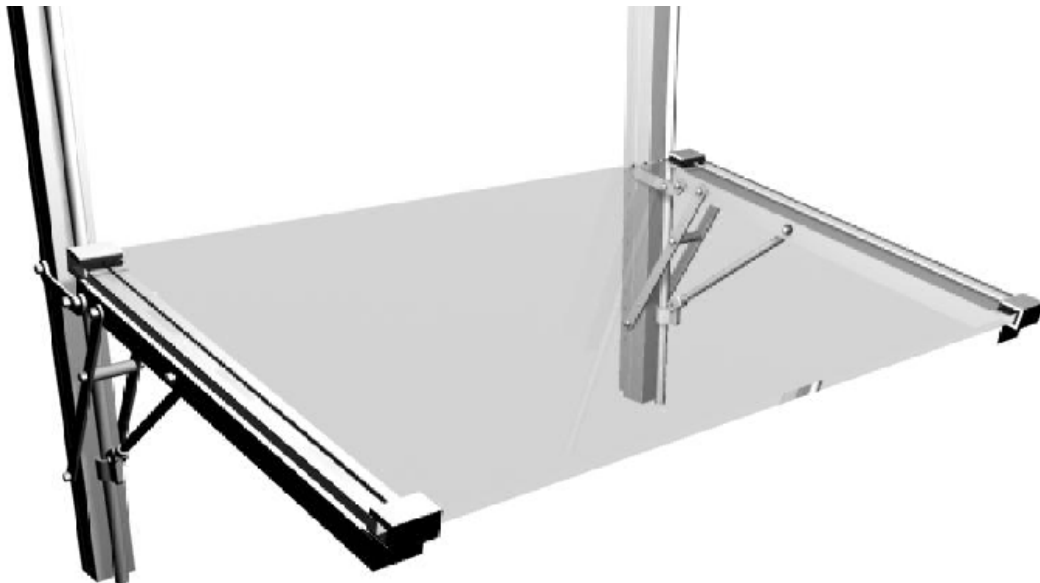

ECLYPSE

Typ: Punktfixierte Glaslamelle

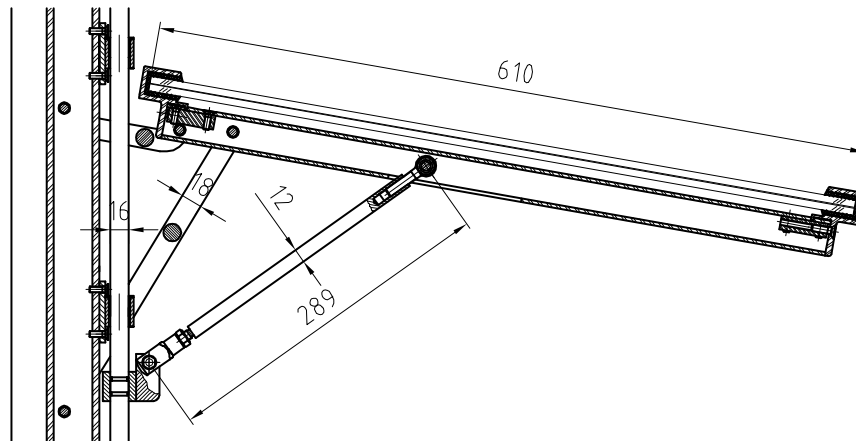

Fragen zu unseren Produkten? Tel.: (0)2157-1416-0 oder info@sun-works-bs.de